

Fitting instructions OmniaGrip

Fibreglass non slip sheet

Clean the Omnia panel from dust and dirt
Wipe with SABA Cleaner 48

Arrange the OmniaGrip sheet on the panel. (Wipe the sheet while unrolling with a moist cloth to remove any dust)
Clamp one edge to fix position and roll the sheet back.
Apply the self adhesive tape over $\frac{3}{4}$ of the surface leaving 25mm (1") around the edge. Make sure no air is trapped under the tape.

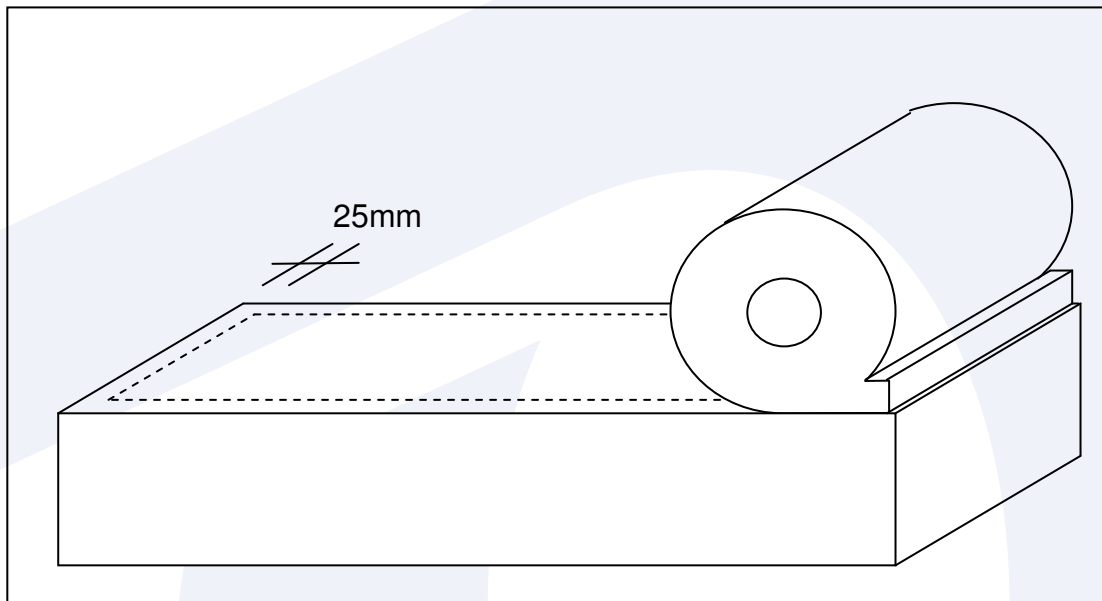

Apply SABA primer 4518 around the edge and let dry for about 10 min.

Apply SABA Sealtack 750 around the edge

Remove silicon paper from the adhesive tape and roll out to OmniaGrip sheet, making sure not to trap any air.

Finish the process for the other $\frac{1}{4}$ of the panel, by rolling the sheet back to other way and applying tape and sealant.

Use a heavy roller to press the OmniaGrip to adhesive on the panel evenly

Clamp down the edges (e.g. with scuff band) of put weight on the full area of the panels for 24 hrs.

